

## High-Pressure Stripped Pump

### Description

The major components of these stripped pump models consist of an air-operated motor that connects directly to a double-acting reciprocating pump tube. The pump tube is equipped with a dynamic primer. See **Figure 2-B**.

These high-pressure stripped pumps (50:1 ratio) are designed to deliver a range of greases [up to NLGI # 2] and operate directly from their original drums or bulk containers. Each pump model is designed with a pump tube length to accommodate different size containers. See **Figure 1**.

### Specifications

#### Air Motor

Piston Diameter x Stroke		Air Inlet	Maximum Air Pressure	
Inches	Centimeters		psi	Bars
3 x 3-5/16	7.6 x 8.4	1/4 " NPTF (f)	150	10.3

For details on the air motor, refer to Service Guide SER 339413

#### Pump Tube

Material Outlet	Max. Material Pressure		Delivery/Minute (Approximate)*		Displacement per Cycle	
	psi	Bars	Pounds	Kilograms	In <sup>3</sup>	Cm <sup>3</sup>
3/8 " NPTF	7500	517	4.7	2.1	0.76	12.5

\* For detailed information, refer to **Figure 3**

**Table 1** High-Pressure Stripped Pump Specifications

### Package Models

The usage for each model of stripped pump is indicated below.

Pump Model	Package Model	Pump Model	Package Model
9911-1	9911-H1, 9911-Z1	9950-1	9950-A1, -HC1, 9951-1, -S1, -T1
9911-R1	9911-A1, 9911-B1	9950-B1	9911-HA1
		9950-C1	9911-HB1

**Table 2** High-Pressure Stripped Pump Usage

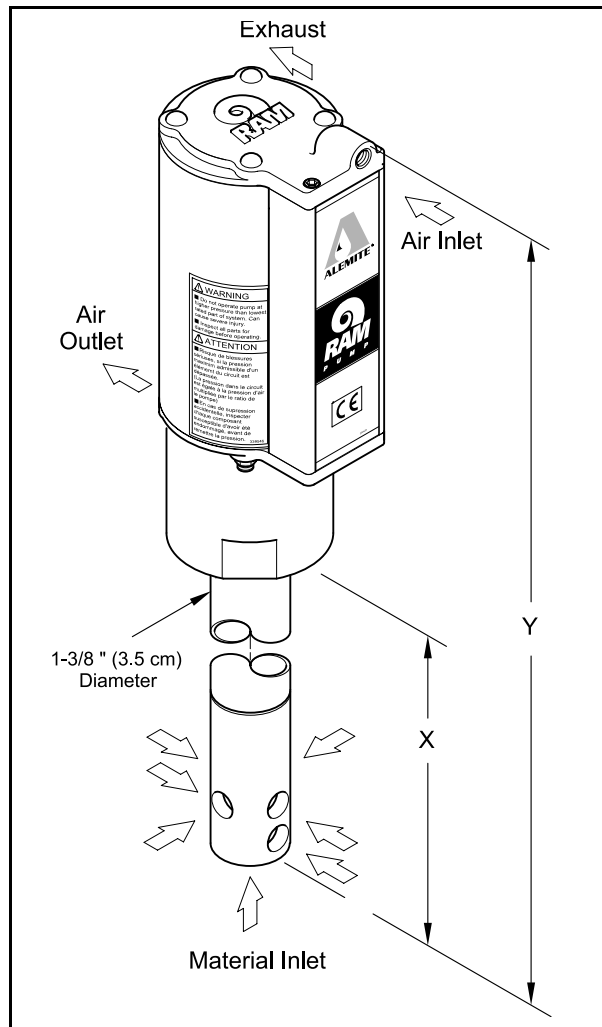

Stripped Pump Model	Container Size		X		Y	
	lbs	kg	Inches	Cm	Inches	Cm
9911-1	35	-	13.75	34.9	23.6	59.9
9911-R1	70	-	17.68	44.9	27.53	69.9
9950-1	120	50	27.75	70.5	37.6	95.4
9950-B1	-	12.5	15.50	39.4	25.35	64.3
9950-C1	-	20	19.00	48.3	28.85	73.2
9950-D1	400	180	37.06	94.1	46.91	119

**Figure 1** High-Pressure Stripped Pump Models 9911-1, 9950-1 Series

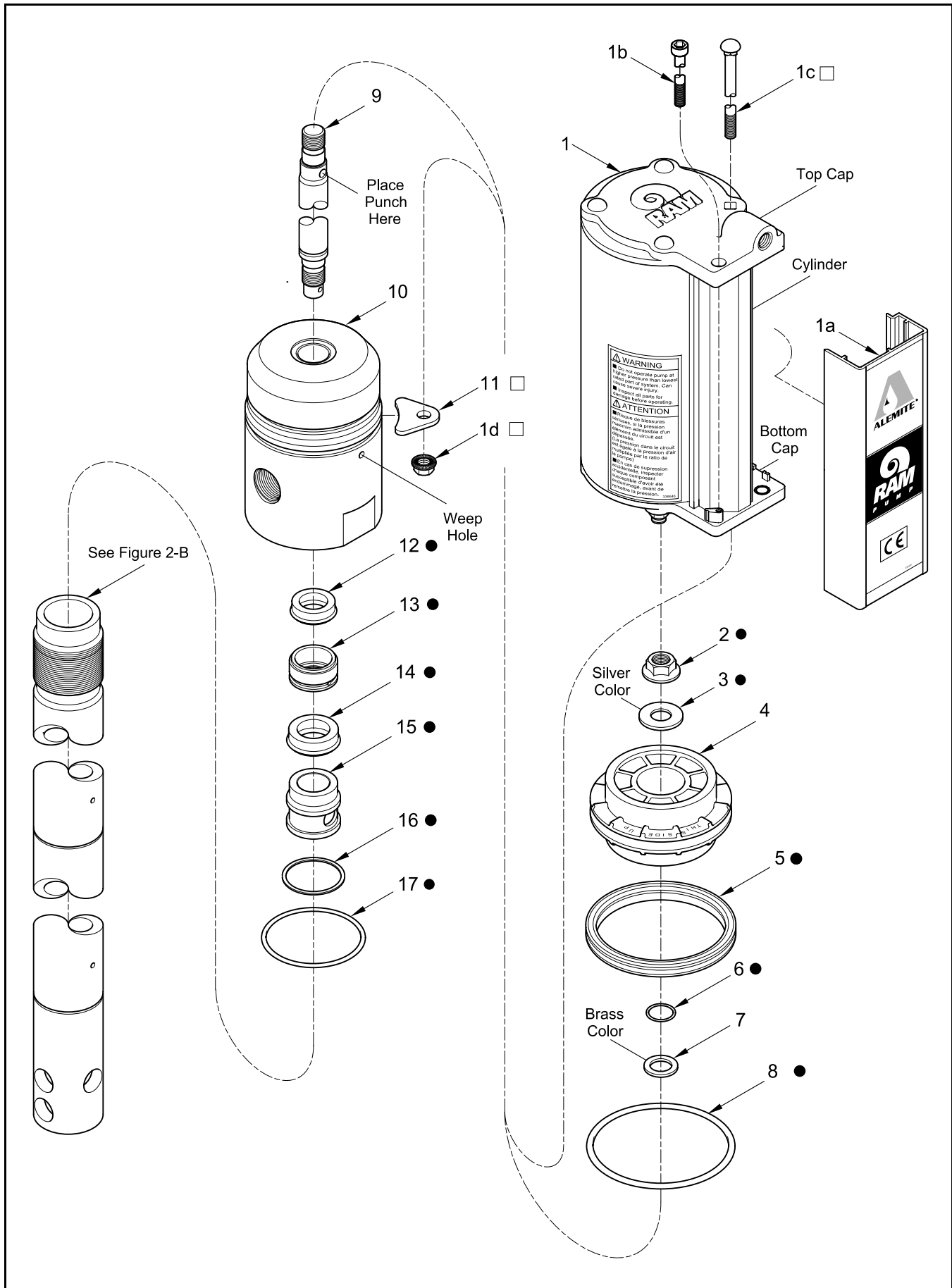

Figure 2 High-Pressure Stripped Pump Models 9911-1 and 9950-1 Series - Exploded View

Item No.	Part No.	Description	Qty	Notes	Numeric Order Part # (Item #)
1		Motor Assembly, Air	1	See SER <b>339413</b>	14536 (3)
1a	340053	Cover (w/o Decals)	1	Included w/ Motor Assembly	X171000-7 (6)
1b		Screw, Cap, 1/4 " -20 x 6-1/2 "	1		X171003-10 (8)
1c		Bolt, Carriage, 1/4 " -20 x 7-1/2 "	4		X171008-37 (5)
1d		Nut, Serrated Flange, 1/4 " -20	4		X171009-45 (17)
2	339513	Nut, Flange, 3/8 " -24	1	●	172190-24 (12)
3		Washer, 3/8 " ID x 7/8 " OD	1	●	172190-26 (14)
4	339429	Piston, Air	1		338072 (13)
5	X171008-37	Quad-Ring, 2-5/8 " ID x 3 " OD	1	●	Pack of Ten (10)
6	X171000-7	O-Ring, 3/8 " ID x 1/2 " OD	1	●	
7	339109	Washer, 3/8 " ID x 3/4 " OD	1		338074 (16)
8	X171003-10	O-Ring, 2-3/4 " ID x 3 " OD	1	●	Pack of Ten (10)
9	338509	Rod	1		338083 (10)
10		Body	1		338109 (7)
11	339412	Keeper	4	□	338509 (9)
12		Seal, 1/2 " ID x 3/4 " OD	1	●	339375 (1d)
13		Ring, Lantern (Brass)	1	●	339412 (11)
14		Seal, 1/2 " ID x 7/8 " OD	1	●	339413 (1)
15		Bearing (Brass)	1	●	339425 (1c)
16		Gasket (Aluminum)	1	●	339429 (4)
17	X171009-45	O-Ring, 2-9/16 " ID x 2-3/4 " OD	1	●	339513 (2)
					340027 (1b)
					340053 (1a)

**Legend:**  
Part numbers left blank (or in *italics*) are not available separately  
● □ designates a repair kit item

### Repair Kits

Part No.	Kit Symbol	Description	Notes
<b>393709</b>	●	Kit, Major Repair [Includes tube of 393590 Teflon Grease]	Contains items on <b>Figures 2-A and 2-B</b>
<b>393708</b>	□	Kit, Repair, Air Motor Keeper	
393530-24		Kit, Seal [includes five (5) of item number <b>12</b> ]	
393530-26		Kit, Seal [includes five (5) of item number <b>14</b> ]	

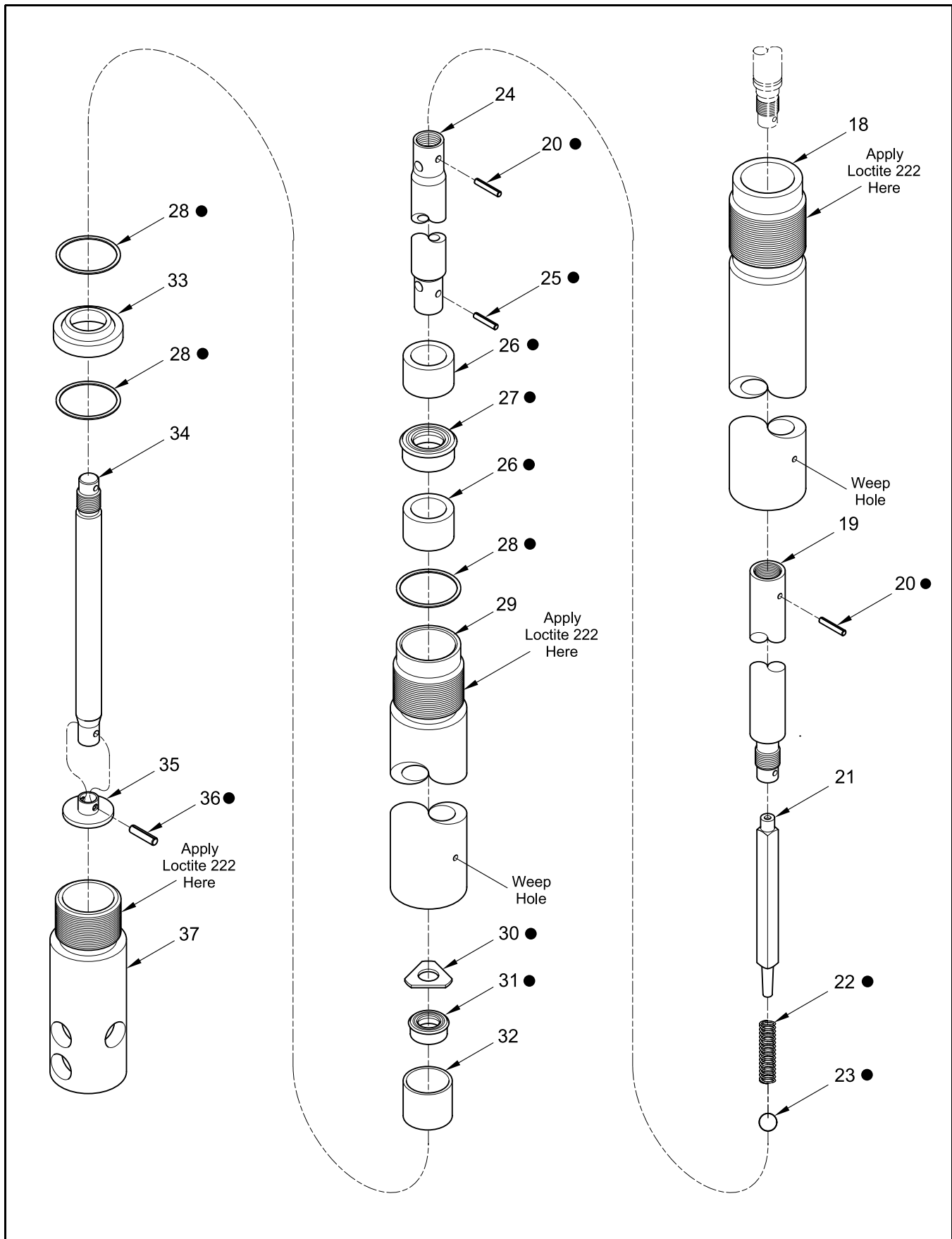

Figure 2-B High-Pressure Grease Pump Model 9911-1 and 9950-1 - Exploded View (Sheet 2 of 2)

Item No.	Part No.	Description	Qty	Notes	Numeric Order Part # (Item #)
18	338508-3	Tube, Upper, 5.78 " Long	1		9911-1 <i>171031-5</i> (25)
	338508-1	Tube, Upper, 19.78 " Long	1		9950-1 <i>171032-3</i> (36)
	338508-7	Tube, Upper, 7.53 " Long	1		9950-B1 171032-6 (20)
	338508-5	Tube, Upper, 11.03 " Long	1		9950-C1 <i>171700-18</i> (23)
	338508-9	Tube, Upper, 29.09 " Long	1		9950-D1 <i>172190-10</i> (31)
	338508-4	Tube, Upper, 9.71 " Long	1		9911-R1 <i>172190-25</i> (27)
19	338055-1	Extension, 14.62 " Long	1		9950-1 338055-1 (19)
	338055-6	Extension, 2.37 " Long	1		9950-B1 338055-3 (19)
	338055-4	Extension, 5.87 " Long	1		9950-C1 338055-4 (19)
	338055-8	Extension, 23.93 " Long	1		9950-D1 338055-6 (19)
	338055-3	Extension, 4.55 " Long	1		9911-R1 338055-8 (19)
20	171032-6	Pin, Roll, 3/32 " Dia. x 5/8 " Long	2	●	Except 9911-1 <i>338056</i> (30)
			1		9911-1 Only 338069 (37)
21	338080	Guide, Spring	1		338070 (33)
22		Spring	1	●	338071 (32)
23		Ball	1	●	338075 (34)
24	338084	Piston	1		<i>338077</i> (28)
25		Pin, Roll, 5/64 " Dia. x 1/2 " Long	1	●	338078 (35)
26		Bearing (Brass)	2	●	<i>338079</i> (22)
27		Seal, 5/8 " ID x 1 " OD	1	●	338080 (21)
28		Gasket (Aluminum)	3	●	<i>338081</i> (26)
29	338085	Tube, Lower	1		338084 (24)
30		Stop	1	●	338085 (29)
31		Seal, 0.282 " ID x 0.532 " OD	1	●	338508-1 (18)
32	338071	Valve, Foot	1		338508-3 (18)
33	338070	Seat	1		338508-4 (18)
34	338075	Rod, Primer	1		338508-5 (18)
35	338078	Disk, Primer	1		338508-7 (18)
36		Pin, Roll, 3/32 " Dia. x 3/8 " Long	1	● <sub>1</sub>	338508-9 (18)
37	338069	Body, Primer	1		

**Legend:**  
Part numbers left blank (or in *italics*) are not available separately  
● designates a repair kit item

### Repair Kits

Part No.	Kit Symbol	Description	Notes
<b>393709</b>	●	Kit, Major Repair (Includes tube of 393590 Teflon Grease)	Contains items on <b>Figures 2-B and 2-A</b>
393530-10		Kit, Seal [includes five (5) of item number <b>31</b> ]	
393530-25		Kit, Seal [includes five (5) of item number <b>27</b> ]	

## Accessories

Part Number	Description
326750-F1	Bung Adapter, 2 " NPTF (m)

**Table 3** High-Pressure Stripped Pump Accessory Component

## Preventive Maintenance

Refer to section entitled **Overhaul** for the procedures necessary to perform maintenance.

Daily	Weekly	Monthly	Yearly
Wipe Exterior with Clean Cloth	Inspect for Air and/or Material Leakage		

**Table 4** High-Pressure Stripped Pump Preventive Maintenance Schedule

## Performance Curves

A pump’s ability to deliver material is based on the pressure (psi/Bars) and quantity (cfm/lpm) of air supplied to the motor and the amount of material discharge [back] pressure to be overcome within the system.

This chart contains curves based on three different air pressures. The curves relate delivery in pounds (kilograms) per minute (X axis) to air consumption in cubic feet (liters) per minute (right Y axis) and to material discharge pressure in psi/Bars (left Y axis).

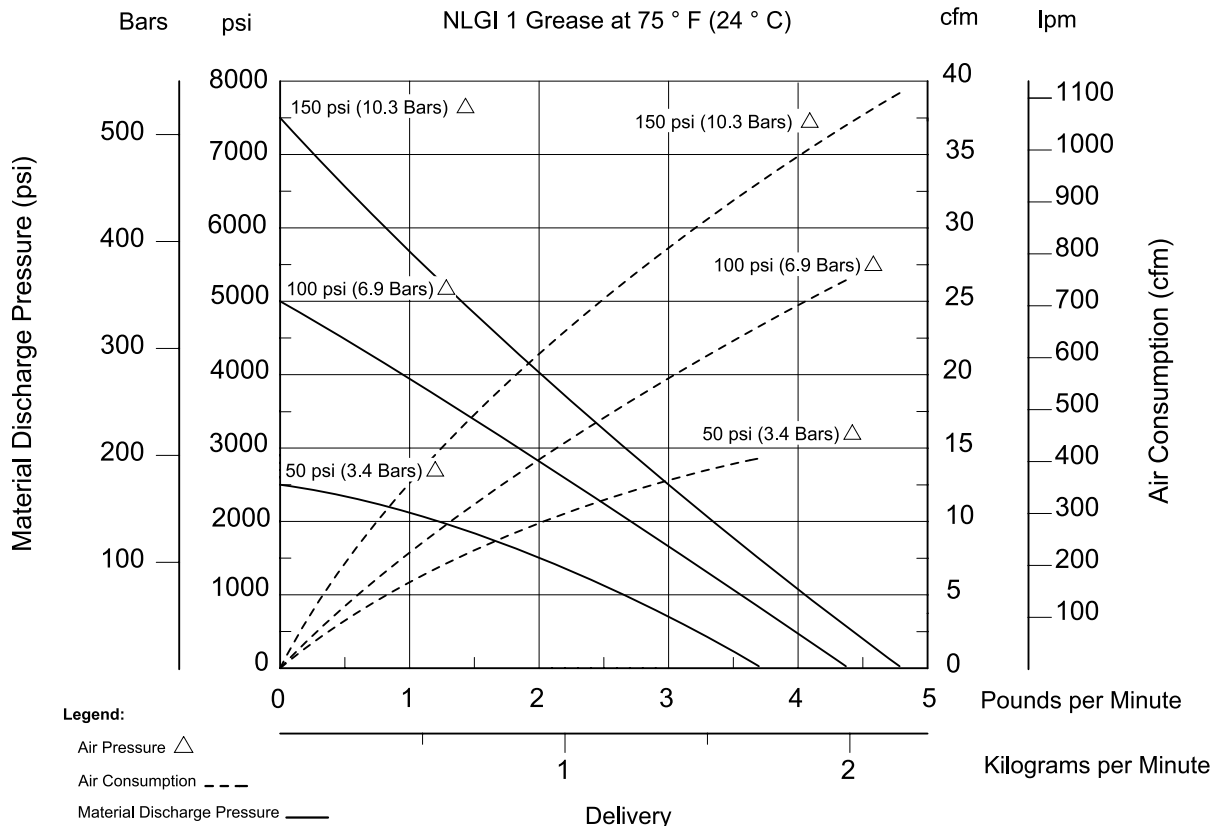

**Figure 3** Delivery versus Discharge Pressure and Air Consumption

## Overhaul

**NOTE:** Refer to **Figures 2-A** and **2-B** for component identification on all overhaul procedures.

Prior to performing any maintenance procedure, the following safety precautions must be observed. Personal injury may occur.



### WARNING

**Do not use halogenated hydrocarbon solvents such as methylene chloride or 1,1,1-trichloroethane in this pump. An explosion can result when aluminum and/or zinc-plated parts in the pump come in contact with halogenated hydrocarbon solvents.**

**Release all pressure within the system prior to performing any overhaul procedure.**

- **Disconnect the air supply line from the pump motor.**
- **Into an appropriate container, operate the control valve to discharge remaining pressure within the system.**

**Never point a control valve at any portion of your body or another person. Accidental discharge of pressure and/or material can result in injury. Read each step of the instructions carefully. Make sure a proper understanding is achieved before proceeding.**

## Disassembly

### Separate Air Motor from Pump Tube

1. Clamp the pump assembly in a soft-jaw vise at Body (10).
2. Remove Cover (1a).
  - Pry and swing the Cover sideways away from the **Cylinder**.
  - Refer to SER 339413 for details.
3. Remove Screw (1b) from the **Top Cap**.
4. Remove Nuts (1d) that secure the Body to Air Motor Assembly (1).
5. Remove Bolts (1c) from the **Top Cap**.
  - Remove Keepers (11) from the Body.
6. Remove the **Top Cap** from the **Cylinder**.

### CAUTION

**Remove the Cylinder with care. Damage to Quad-Ring (5) and/or O-Ring (8) can occur.**

7. With a side-to-side motion, pull the **Cylinder** from the Body and Air Piston (4).
8. Remove O-Ring (8) from the Body.
9. Remove the **Bottom Cap** from the Body.

### Pump Tube Assembly

#### Air Piston

10. Remove Nut (2) and Washer (3) that secures Air Piston (4) to Rod (9).
  - Place a punch or similar tool into the Rod to prevent its rotation. See **Figure 2-A**.
  - Remove the Air Piston from the Rod.
11. Remove Quad-Ring (5) from the Air Piston.
12. Remove O-Ring (6) and Washer (7) from the Rod.

#### Body Assembly

13. Unscrew Upper Tube (18) from the Body.
14. Remove the Body assembly from the Rod.
15. From inside the Body remove:
  - Gasket (16)
  - Bearing (15)
  - Seal (14)
  - Lantern Ring (13)
  - Seal (12)

#### Tube Assembly

16. Push the Rod assembly downward through Upper Tube (18) until Primer Disk (35) protrudes from Primer Body (42).
17. Remove Roll Pin (36) that secures the Primer Disk to Primer Rod (34).
  - Remove the Primer Disk from the Primer Rod.
18. Remove the entire Rod assembly from the top of the Upper Tube.
19. Remove Roll Pin (25) that secures the Primer Rod to Piston (24).
  - Unscrew the Primer Rod from the Piston.

**Step for Model 9911-1 Only**

20. Remove Roll Pin (25) that secures Rod (9) to the Piston.
  - Unscrew the Piston from the Rod.

**Step for all Models Except 9911-1**

21. Remove Roll Pin (25) that secures Rod (9) to the Extension.
  - Unscrew the Extension from the Rod.

22. From inside the Piston remove:

- Spring Guide (21)
- Spring (22)
- Ball (23)

23. Unscrew the Upper Tube from Lower Tube (29).
  - Use a strap wrench.

**Lower Tube**

24. Remove Gasket (28), Bearing (26), Seal (27), and additional Bearing (26) from the Lower Tube.

**Primer Body**

25. Unscrew Primer Body (37) from the Lower Tube.

26. From inside the Lower Tube remove:

- Gasket (28)
- Seat (33)
- additional Gasket (28)
- Foot Valve (32) [with Seal (31)]
- Stop (30)

27. Remove the Seal from the Foot Valve.

**Clean and Inspect**

1. Clean all metal parts in cleaning solvent. The solvent should be environmentally safe.
2. Inspect all parts for wear and/or damage.
  - Replace as necessary.
3. Inspect Air Piston (4) for fatigue cracks.
  - Replace as necessary.
4. Inspect Rod (9), Piston (24), and Primer Rod (34) closely. Use a magnifying glass to detect any score marks.
  - Replace as necessary.
5. Closely inspect the mating surfaces of all check valve components for any imperfections. Ensure a smooth and clean contact is obtained when assembled.

**EXAMPLE:** Place Ball (23) into Piston (24). Fill the Piston with solvent. Make sure no leakage occurs.

**Assembly**

**NOTE:** Prior to assembly, certain components require lubrication. Refer to **Table 3** for details.

Refer to **Figure 4** for a section view of the pump tube assembly.

**Pump Tube Assembly**

1. Install and seat Seal (12) [heel end first] into the bottom of the Body.
2. Install and seat Lantern Ring (13) [small diameter end first] into the Body.
3. Install and seat Seal (14) [heel end first] into the Body.

Item No.	Description	Item No.	Description
<b>Clean Oil</b>			
5	Quad-Ring, 2-5/8 " ID x 3 " OD	14	Seal, 1/2 " ID x 7/8 " OD
6	O-Ring, 3/8 " ID x 1/2 " OD	17	O-Ring, 2-9/16 " ID x 2-3/4 " OD
8	O-Ring, 2-3/4 " ID x 3 " OD	27	Seal, 5/8 " ID x 1 " OD
12	Seal, 1/2 " ID x 3/4 " OD	31	Seal, 0.282 " ID x 0.532 " OD
<b>Magnalube-G Teflon Grease *</b>			
Coat the Bore of the Air Motor Assembly			
* Part number 393590 is a 0.75 ounce (21.8 gm) tube of Magnalube-G Teflon grease			

**Table 3** Lubricated Components



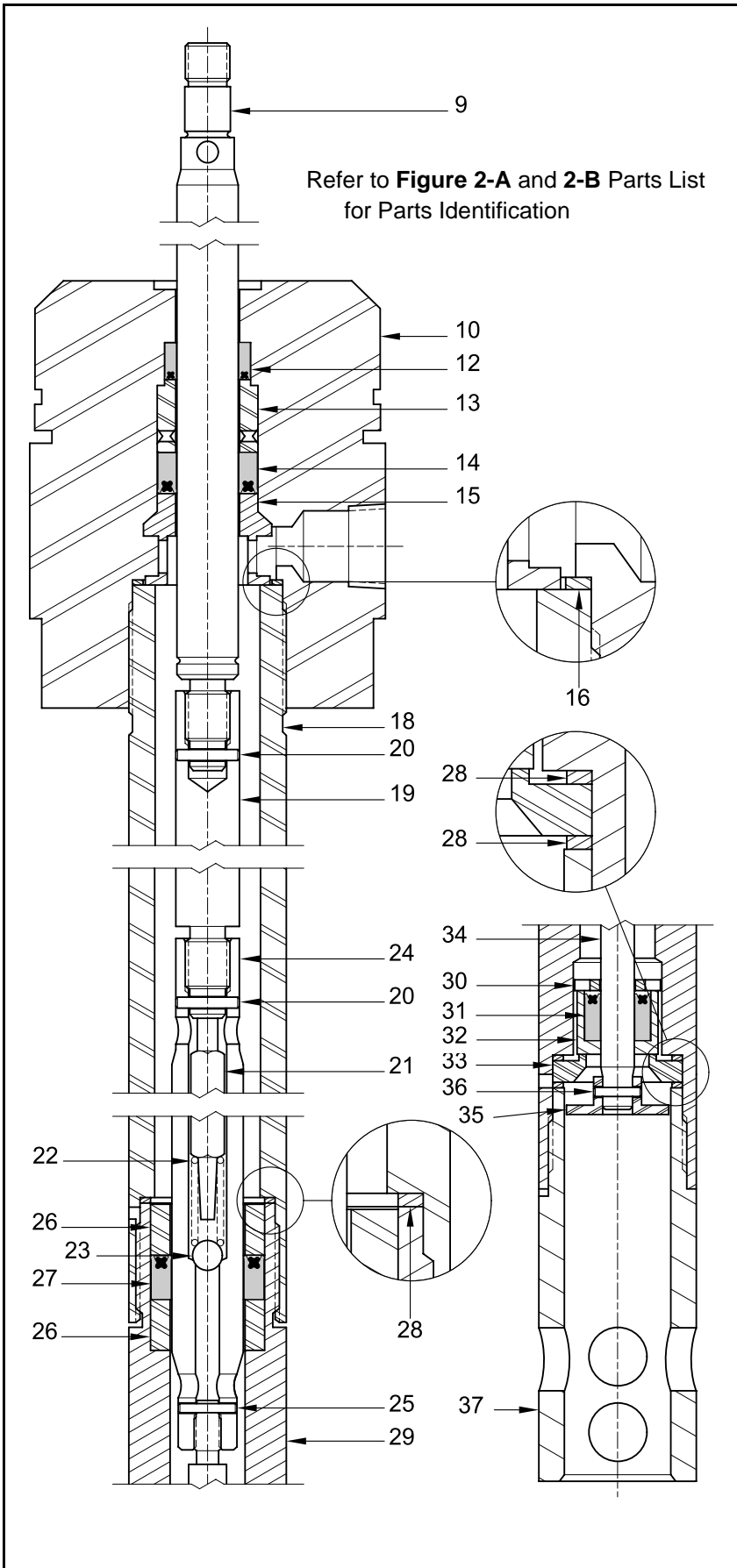

**Figure 4** Pump Tube Assembly - Section View

4. Install and seat Bearing (15) [small diameter end first] into the Body.
5. Install and seat Gasket (16) into the Body.

**Step for all Models Except 9911-1**

6. Screw Rod (9) into Extension (19) until the Pin holes align.
  - Secure the Extension to the Rod with Roll Pin (20).

7. Install Ball (23), Spring (22), and Spring Guide (21) [pointed end first] into Piston (24).

**Step for all Models Except 9911-1**

8. Screw the Piston assembly onto the Extension until the Pin holes align.
  - Secure the Piston to the Extension with Roll Pin (20).

**Step for Model 9911-1 Only**

9. Screw the Piston assembly onto the Rod until the Pin holes align.
  - Secure the Piston to the Rod with Roll Pin (20).

10. Screw Primer Rod (34) into the Piston assembly until the Pin holes align.
  - Secure the Piston assembly to the Primer Rod with Roll Pin (25).

11. Install and seat Bearing (26), Seal (27) [heel end first], and additional Bearing (26) into the externally threaded end of Lower Tube (29).

12. Install and seat Gasket (28) into the internally threaded end of Upper Tube (18).

*IMPORTANT: If a primer is used with Loctite 222, the curing time is greatly reduced.*

13. Screw the Lower Tube [with Loctite 222] into the Upper Tube.
  - Follow the thread sealant manufacturer's recommendations.
  - Do not tighten at this time.

14. Install the Rod assembly into the Upper Tube until it protrudes from the Lower Tube.
  - Use care not to damage the Seal.
15. Install Seal (31) [heel end first] into Foot Valve (32).
16. Install Stop (30), the Foot Valve assembly [Seal end first], Gasket (28), Seat (33) [small diameter end first], and additional Gasket (28) over the Primer Rod and into the Lower Tube.
17. Install Primer Disk (35) onto the Primer Rod.
  - Make sure the hole align.
18. Install Roll Pin (36) that secures the Primer Disk to the Primer Rod.
19. Screw Primer Body (37) [with Loctite 222] into the Lower Tube.
  - Follow the thread sealant manufacturer's recommendations.
  - Do not tighten at this time.

---

### CAUTION

**Install the Rod and Tube assembly into the Body with a twisting motion. Use care not to damage the Seals.**

---

20. Install the Rod and Tube assembly into the Body and at the same time screw the Upper Tube [with Loctite 222] into the Body.
  - Follow the thread sealant manufacturer's recommendations.
21. Tighten all the threaded pump tube components into one another.
  - Place a bar or other suitable tool in the holes of the Primer Body for leverage.
  - Tighten sufficiently to properly crush all Gaskets.

#### Air Piston

---

### CAUTION

**Use care not to switch Washers (3 and 7). Component damage can occur.**

---

22. Install Washer (7) [brass color] and O-Ring (6) onto the Rod.
23. Install Quad-Ring (5) onto Air Piston (4).
24. Place the Air Piston (observe THIS SIDE UP) on top of the Rod.

25. Install Washer (3) [silver color] and Nut (2) that secures the Air Piston to the Rod.
  - Tighten the Nut securely.

**NOTE:** Place an appropriate size punch or other suitable tool into the hole of the Rod. See **Figure 2-A**.

#### Attach Air Motor to Pump Tube

26. Clamp the pump at the flats of Body (10) securely in a soft-jaw vise.
27. Install the **Bottom Cap** onto the Body.
28. Install O-Ring (8) onto the upper groove of the Body.

---

### CAUTION

**Install the Cylinder with care. Damage to Quad-Ring (5) and/or O-Ring (8) can occur.**

---

**HINT:** Angle the **Cylinder** onto the Quad-Ring.

29. Install the **Cylinder** over the Body's O-Ring and seat it properly onto the **Bottom Cap**.
30. Install the **Top Cap** onto the **Cylinder**.
  - Use care passing the O-Ring.
31. Install Keeper (11) into the groove of the Body.
  - Make sure the hole aligns with Carriage Bolt (1c).
32. Install one Carriage Bolt through the Air Motor and through the Keeper.
33. Install Flange Nut (1d).
  - Do not tighten the Flange Nut at this time.
34. Repeat procedural steps 31 - 33 for the additional Keepers and Carriage Bolts.

---

### CAUTION

**Do not overtighten Flange Nuts (1d). Component damage can occur.**

---

35. Torque each Flange Nut in an alternate pattern from 60 to 70 inch-pounds (6.8 - 7.9 Nm).
36. Install Screw (1b) into the **Top Cap**.
  - Tighten the Screw to 50 inch-pounds (5.6 Nm).
37. "Snap" Cover (1a) onto the **Cylinder**.

## Bench Test and Operation

1. Slowly supply air pressure [recommended minimum of 25 psi (1.7 Bars)] to the pump's motor.
  - The pump assembly should cycle.

If the pump assembly does not cycle, refer to the **Troubleshooting Chart** for details.

With air pressure at zero:

2. Connect a product hose to the pump's material outlet.
  - Direct the hose into an appropriate collection container.
3. Place the pump in grease.
4. Slowly supply air pressure to the pump's motor.
5. Allow the pump to cycle slowly until the grease is free of air.

If the pump assembly does not prime, refer to the **Troubleshooting Chart** for details.



### WARNING

**Should leakage occur anywhere within the system, disconnect air to the motor. Personal injury can occur.**

With air pressure at zero:

6. Attach a control valve to the outlet hose of the pump.
  - Make sure the nozzle on the control valve is open.
7. Slowly supply air pressure to the pump's motor.
8. Allow the pump to cycle slowly until the grease is once again free of air.
9. Set the air pressure to the normal operating pressure.
10. Operate the control valve into a container.
11. Shut off the control valve.
  - Visually inspect the pump for external leaks.
  - The pump should not cycle more than once or twice in one hour.

If the pump does not stall, refer to the **Troubleshooting Chart** for details.

12. Check the motor for air leakage.

If the motor leaks, refer to the **Air Motor Service Guide** for details.

## Installation

Additional items that should be incorporated into the air piping systems are listed in **Table 5**.

Part Number	Description
5604-2	Moisture Separator
7604-B	Regulator and Gauge

**Table 5** *Air Line Components*

## Troubleshooting Chart

Pump Indications	Possible Problems	Solution
Pump does not cycle	<ol style="list-style-type: none"> <li>1. Air motor not operating properly</li> <li>2. Pump tube jammed and/or contains loose components</li> <li>3. Insufficient air pressure</li> </ol>	<ol style="list-style-type: none"> <li>1. Inspect air motor and rebuild or replace as necessary</li> <li>2. Rebuild pump tube</li> <li>3. Increase air pressure</li> </ol>
Pump will not prime	<ol style="list-style-type: none"> <li>1. Excessive cycling speed</li> <li>2. Pump leaking internally</li> </ol>	<ol style="list-style-type: none"> <li>1. Reduce air pressure</li> <li>2. See <b>Internal Leaks</b></li> </ol>
Pump cycles rapidly	Product source empty	Replenish product
Pump will not stall (cycles more than once or twice/hour)	<ol style="list-style-type: none"> <li>1. Pump requires break-in period</li> <li>2. Pump leaking internally</li> <li>3. Pump leaking externally</li> <li>4. Distribution system leaking</li> </ol>	<ol style="list-style-type: none"> <li>1. Operate the pump against moderate fluid pressure for up to one hour</li> <li>2. See <b>Internal Leaks</b></li> <li>3. See <b>External Leaks</b></li> <li>4. Correct leak</li> </ol>
<b>External Leaks</b>		
Product leakage visible at weep hole in Body (10)	<ol style="list-style-type: none"> <li>1. Damaged Seal (14)</li> <li>2. Damaged Rod (9)</li> </ol>	<ol style="list-style-type: none"> <li>1. Replace Seal (14)</li> <li>2. Inspect Rod (9) and replace as necessary</li> </ol>
Product leakage visible at bottom of Body (10)	<ol style="list-style-type: none"> <li>1. Upper Tube (18) not sufficiently tight</li> <li>2. Damaged Gasket (16)</li> </ol>	<ol style="list-style-type: none"> <li>1. Tighten Upper Tube (18) into Body (10)</li> <li>2. Replace Gasket (16)</li> </ol>
Air leakage at weep hole in Body (10)	<ol style="list-style-type: none"> <li>1. Damaged Seal (12)</li> <li>2. Damaged Rod (9)</li> </ol>	<ol style="list-style-type: none"> <li>1. Replace Seal (12)</li> <li>2. Inspect Rod (9)</li> </ol>
Product leakage visible at weep hole in Upper Tube (18)	<ol style="list-style-type: none"> <li>1. Lower Tube (29) not sufficiently tight</li> <li>2. Damaged Gasket (28)</li> </ol>	<ol style="list-style-type: none"> <li>1. Tighten Lower Tube (29) into Upper Tube (18)</li> <li>2. Replace Gasket (28)</li> </ol>
Product leakage visible at weep hole in Lower Tube (29)	<ol style="list-style-type: none"> <li>1. Primer Body (37) not sufficiently tight</li> <li>2. Damaged Gasket(s) (28)</li> </ol>	<ol style="list-style-type: none"> <li>1. Tighten Primer Body (37) into Lower Tube (29)</li> <li>2. Replace Gasket(s) (28)</li> </ol>
<b>Internal Leaks</b>		
Pump does not prime or cycles continuously, or slowly (once or twice/hour)	<ol style="list-style-type: none"> <li>1. Foreign material between Ball (23) and Piston (24)</li> <li>2. Foreign material between Foot Valve (32) and Seat (33)</li> <li>3. Worn or damaged Ball (23)</li> <li>4. Worn or damaged Piston (24)</li> <li>5. Worn or damaged Foot Valve (32)</li> <li>6. Worn or damaged Seat (33)</li> <li>7. Worn or damaged Seal (27)</li> <li>8. Worn or damaged Seal (31)</li> <li>9. Worn or damaged Primer Rod (34)</li> </ol>	<p>Locate and eliminate source of foreign material</p> <p>Disassemble pump tube, clean, inspect, and replace worn or damaged components</p>

**Changes Since Last Printing**

Changed **Figure 2**