



Service Guide

7492
7498 7498-A
7498-B 7498-C

Non-Metered Control Valve

Description and Operation

The control valves included in models 7492 and 7498 series are designed to dispense a variety of lubricating fluids.

Each model of control valve contains a 40-mesh strainer.

Model 7492 and 7498 Series

The extension and nozzle on each model is designed for different applications. Refer to **Figures 1** and **2** for details.

Control Valve Operation

To begin, press the button in the center of the lever. This releases the safety. With the button held, squeeze the lever to open the valve.

To latch the valve in the full open position, release the lever (while pressing the button), then release the button. To shut the valve off, press the lever and release.

NOTE: The latch feature can be disabled with the removal of a roll pin. See **Figure 4**.

Specifications

Fluid Inlet (Swivel)	Fluid Outlet (at Valve Handle)	Max. Operating Pressure	
		psi	Bars
1/2 " NPTF (f)	1/2 " NPTF (f)	1500	103

Table 1 Model 7492 and 7498 Series Specifications

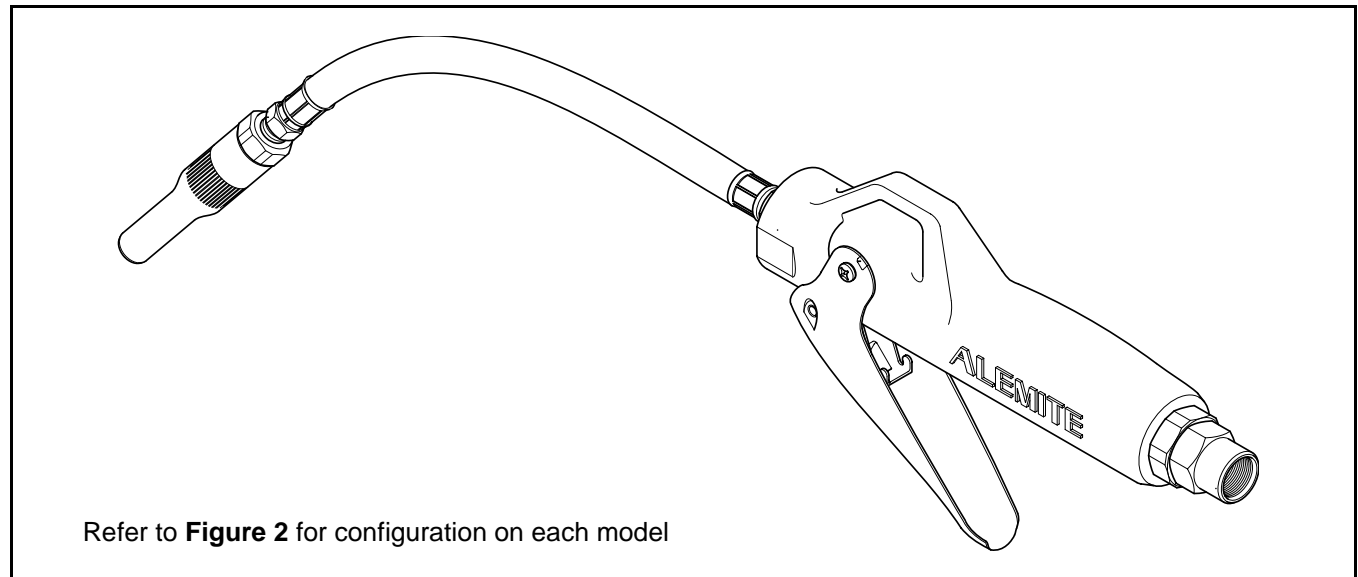

Refer to **Figure 2** for configuration on each model

Valve Model	Extension	Nozzle Type
7492	Rigid	Non-Drip Automatic (with Manual Lock)
7498	Rigid	Non-Drip Automatic
7498-A	Flexible	Non-Drip Automatic
7498-B (Obsolete)	Rigid	Non-Drip High-Volume Automatic
7498-C		Non-Drip High-Volume Manual

Figure 1 Control Valve Model 7492 and 7498 Series - Model 7498-A Shown

Alemite Corporation
167 Rowland Drive, Johnson City, Tennessee 37601
www.alemite.com

Copyright © 2004 by Alemite Corporation

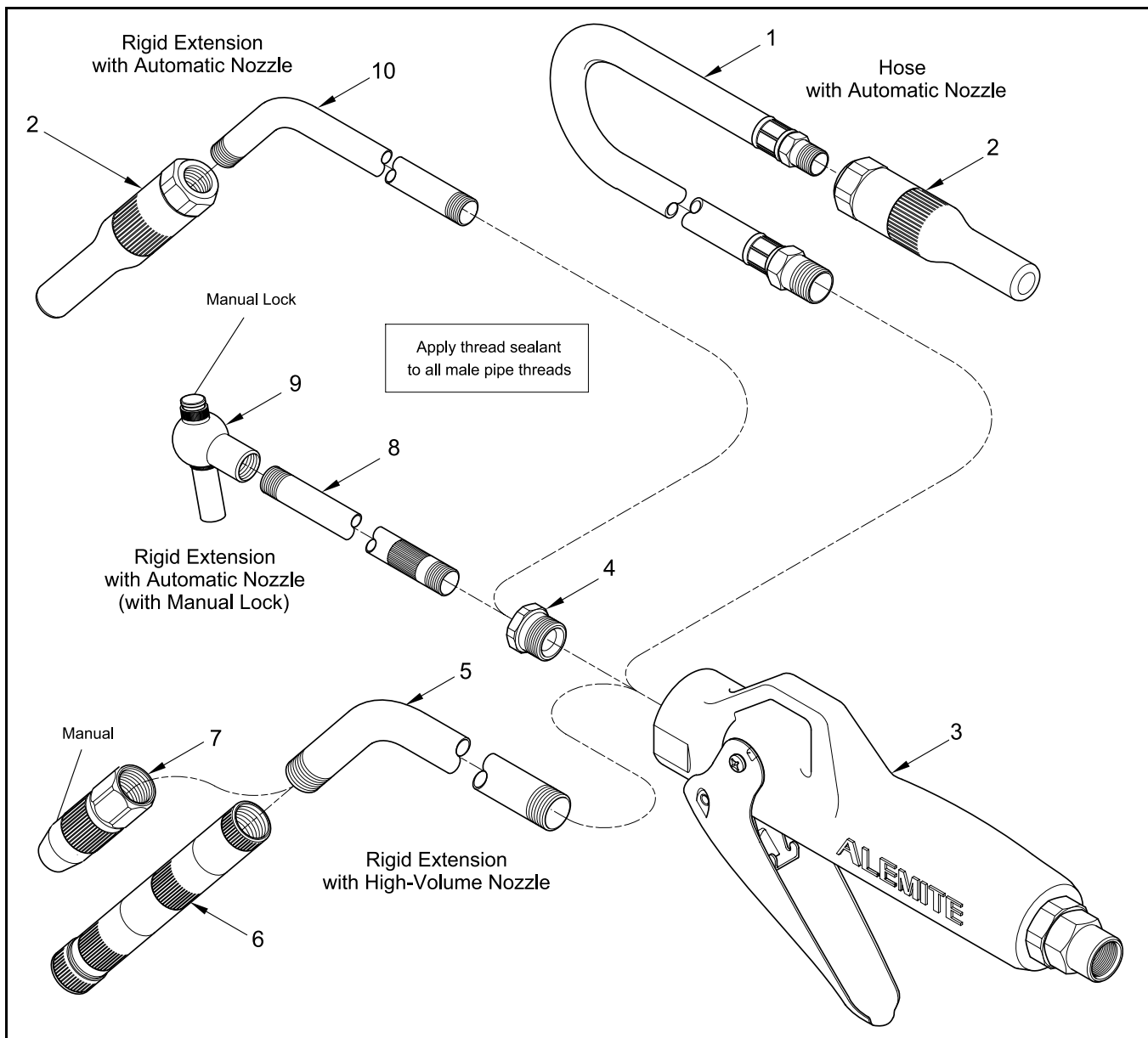

Item No.	Part No.	Description	Qty	Model and Notes	Numeric Order Part # (Item #)
1	338709	Hose, 1/2 " NPTf (m) x 1/4 " NPTF (m)	1	7498-A	51891 (4)
2	B339800	Non-Drip Nozzle, Automatic	1	7498, 7498-A	318400-2 (9)
3	339100	Handle Assembly, Control Valve	1	See Figure 4	320421 (8)
4	51891	Bushing, 1/2 " NPTf (m) x 1/4 " NPTF (f)	1	7492, 7498	332892 (6)
5	339149	Extension, Curved, 1/2 " NPTF (m)	1	7498-B, 7498-C	338702 (10)
6		Non-Drip Nozzle, High-Volume Automatic	1	Obsolete	338709 (1)
7	340084	Non-Drip Nozzle, High-Volume Manual	1	7498-C	339100 (3)
8	320421	Extension, Straight, 1/4 " NPTF (m)	1	7492	339149 (5)
9	318400-2	Non-Drip Nozzle, Automatic (w/ Manual Lock)	1	7492	B339800 (2)
10	338702	Extension, Curved, 1/4 " NPTF (m)	1	7498	340084 (7)

Figure 2 Control Valve Model 7492 and 7498 Series - Exploded View

Service Hints

Refer to the Overhaul Procedures for Details

Do not Apply Thread Sealant to the First Two (2) Threads of any Connection

Contamination can Occur

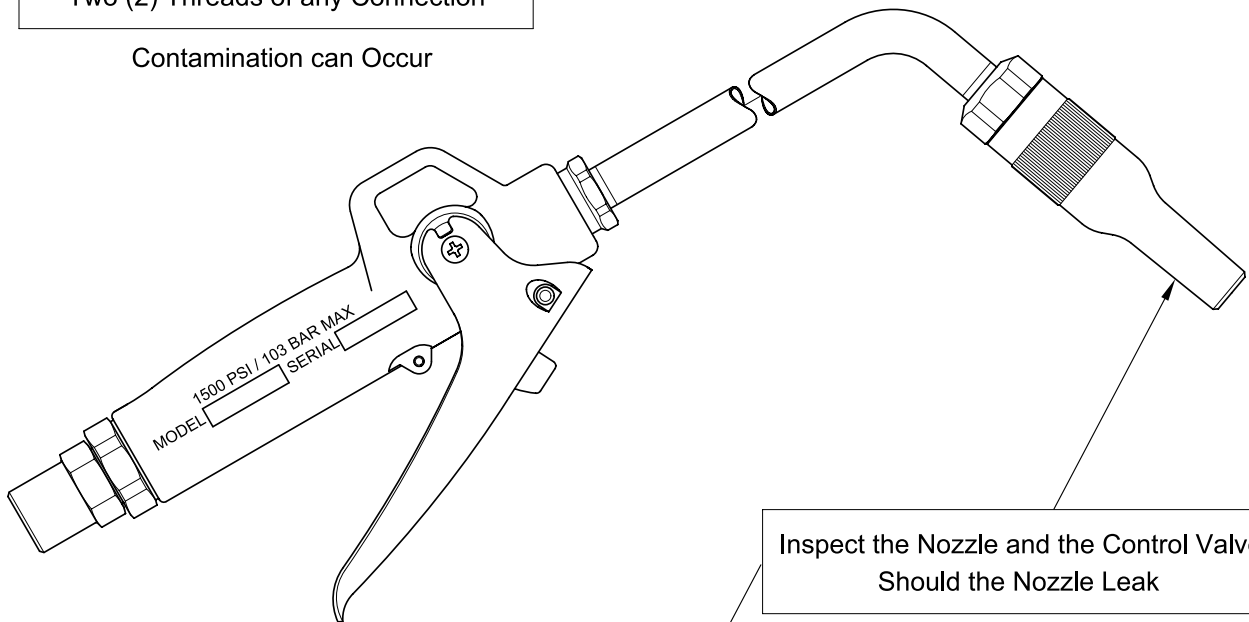

Inspect the Nozzle and the Control Valve
Should the Nozzle Leak

Control Valve Leakage will Cause
Nozzle to Leak

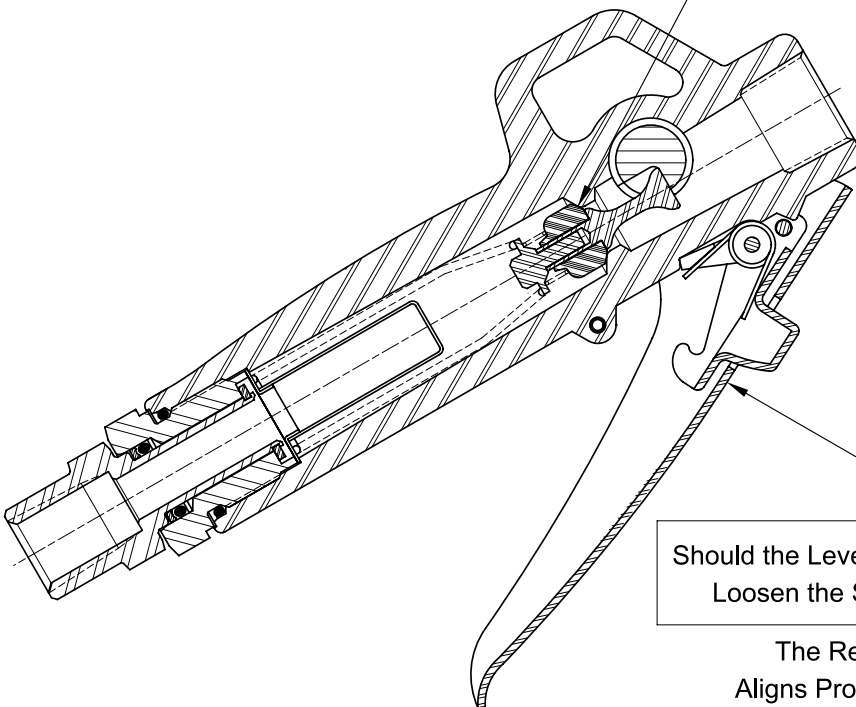

Should the Lever Assembly Require Replacement,
Loosen the Swivel Assembly from the Body

The Replacement Lever Assembly
Aligns Properly with the Tabs on the Cam

Overhaul

NOTE: Refer to **Figure 2** for component identification on the major components of the valve assembly.

Prior to performing any maintenance procedure, the following safety precautions must be observed. Personal injury may occur.



WARNING



Do not use halogenated hydrocarbon solvents such as methylene chloride or 1,1,1 trichloroethane in this valve assembly. An explosion can result within an enclosed device capable of containing pressure when aluminum and/or zinc-plated parts come in contact with halogenated hydrocarbon solvents.

Release all pressure within the system prior to performing any overhaul procedure.

- Disconnect the air supply line from the pump motor.
- Into an appropriate container, operate the control valve to discharge remaining pressure within the system.

Never point a control valve at any portion of your body or another person. Accidental discharge of pressure and/or material can result in personal injury.

Read each step of the instructions carefully. Make sure a proper understanding is achieved before proceeding.



Disassembly

Non-Metered Control Valve

NOTE: The following procedures pertain to all models of non-metered control valves.

1. Unscrew the extension assembly from Control Valve Handle Assembly (3).
2. Separate the components of the extension assembly.

Non-Drip Nozzle (Automatic w/ Manual Lock)

3. Unscrew Nozzle (11) from Angle Body (16).
4. Remove O-Ring (12) from the Nozzle.
5. Remove Stem (14) from the Nozzle.

6. Remove V-Block (13) and Spring (15) from the Stem.
7. Unscrew Screw Assembly (19) from the Angle Body.
8. Remove Washer (18) from the Screw Assembly.
9. Remove Gasket (17) from the Angle Body.

Item No.	Description	Notes	Qty
11	Nozzle		1
12	O-Ring, 1/2 " ID x 5/8 " OD	☐	1
13	V-Block	☐	1
14	Stem	☐	1
15	Spring	☐	1
16	Body, Angle		1
17	Gasket	☐	1
18	Washer	☐	1
19	Screw Assembly		1

Legend:
 Parts are not available separately
 ☐ designates a repair kit item

Repair Kit

Part No.	Kit Symbol	Description
393518	☐	Kit, Repair

Figure 3 Nozzle Assembly 318400-2 - Exploded View

Control Valve Handle

NOTE: Refer to **Figure 4** for component identification.

1. Unscrew Swivel Assembly (29) from Body (20).
2. Remove O-Ring (28) from the Swivel Assembly.
3. Remove Strainer (27), Compression Spring (26), and Spring Support (25) from the Body.
4. Remove Small Compression Spring (24), Seal (23), and Push Rod (22) from the Body.
5. Remove Screws (39) that secure Lever Assembly (38) to Cam (41).
 - Remove the Lever Assembly from the Cam.

NOTE: The Lever Assembly is serviced as an assembly.

6. Remove the Cam from the Body.
7. Remove O-Rings (32) from the Cam.
8. Remove Roll Pin (21) from the Body as required.

Clean and Inspect

NOTE: Use a repair kit for replacement parts. Make sure all the components are included in the kit before discarding used parts.

1. Clean all metal parts in cleaning solvent. The solvent should be environmentally safe.
2. Inspect all parts for wear and/or damage.
 - Replace as necessary.
3. Closely inspect the mating surfaces of all components for any imperfections. Ensure a smooth and clean contact is obtained when assembled.

Item No.	Description
Clean Oil	
12	O-Ring, 1/2 " ID x 5/8 " OD
28	O-Ring, 13/16 " ID x 1 " OD
Multi-Purpose Grease	
32	O-Ring, 1/2 " ID x 11/16 " OD

Table 2 Lubricated Components

Assembly

NOTE: Prior to assembly, certain components require lubrication. Refer to **Table 2** for details.

Control Valve Handle

NOTE: Refer to **Figure 5** for a section view of the control valve handle assembly.

1. Install Roll Pin (21) into Body (20) as required.

IMPORTANT: Lubricate O-Rings (32) with grease prior to installation.
2. Install O-Rings (32) onto Cam (33).
3. Install the Cam assembly into the Body.
 - Make sure to orient the Cam as shown in **Figure 4**.
4. Position Lever Assembly (30) onto the tabs of the Cam.
 - Make sure the safety does not interfere with the Body.
5. Install Screws (31) that secure the Lever Assembly to the Cam.
 - Tighten the Screws securely.
6. Install Seal (23) [blunt end first] onto Push Rod (22).
7. Install Spring Support (25) into the small end of Compression Spring (26).
8. Install Small Compression Spring (24) onto the Spring Support.
9. Install the Push Rod and Seal assembly onto the Spring Support.
10. Install the Compression Spring (with assembled components) into the Body.
 - Make sure the Push Rod seats properly on the Cam.
11. Install Strainer (27) into the Compression Spring.
12. Install O-Ring (28) onto Swivel Assembly (29).

NOTE: Swivel Assembly is under Spring pressure during installation.
13. Screw the Swivel Assembly into the Body.
 - Tighten the Swivel Assembly securely.

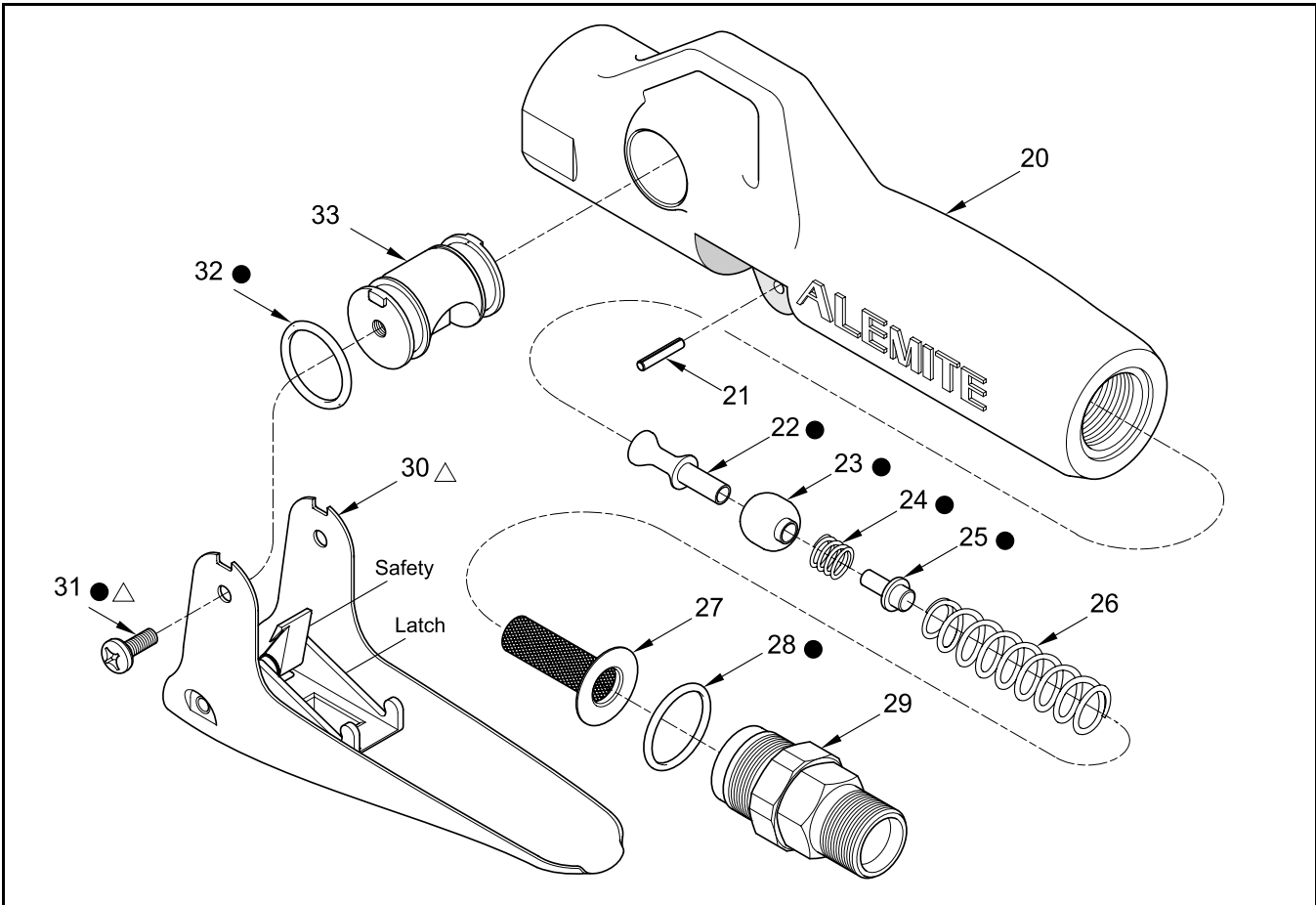

Item No.	Part No.	Description	Qty	Notes	Numeric Order Part # (Item #)
20		Body	1		(30)
21		Pin, Roll, 1/8 " x 5/8 " Long	1		X171000-10 (32)
22		Rod, Push	1	●	X171009-17 (28)
23		Seal	1	●	171033-5 (21)
24		Spring, Compression, Small	1	●	339055 (33)
25		Support, Spring	1	●	339056 (22)
26	339063	Spring, Compression	1		339063 (26)
27	339064	Strainer (40-Mesh)	1		339064 (27)
28	X171009-17	O-Ring, 13/16 " ID x 1 " OD	1	●	339066 (20)
29	339656	Swivel Assembly	1		339067 (25)
30		Lever Assembly	1	△	339068 (24)
31		Screw, 10 -24 x 3/8 "	2	● △	339069 (23)
32	X171000-10	O-Ring, 1/2 " ID x 11/16 " OD	2	●	339070 (31)
33	339055	Cam	1		339656 (29)

Legend:

Part numbers left blank (or in Italics) are not serviced separately
 Part numbers with an X prefix indicate a quantity of ten (10)
 ● △ designates a repair kit item

Repair Kits

Part No.	Kit Symbol	Description
393676	●	Kit, Major Repair
393677	△	Kit, Lever Replacement

Figure 4 Control Valve Handle 339100 - Exploded View

Non-Drip Nozzle (Automatic w/ Manual Lock)

NOTE: Refer to **Figure 3** for component identification.

14. Install Gasket (17) into Angle Body (16).
15. Install Washer (18) into Screw Assembly (19).
16. Thread the Screw Assembly into the Angle Body.
 - Tighten the Screw Assembly securely.
17. Install O-Ring (12) onto Nozzle (11).
18. Install and seat V-Block (13) [concave first] onto the pointed end of Stem (14).
19. Install the Stem assembly [point first] into the Nozzle.
20. Install Spring (15) into the Stem.
21. Screw the Nozzle assembly into Angle Body.
 - Tighten the Nozzle securely.

Non-Metered Control Valve

IMPORTANT: Apply thread sealant to all pipe thread connections prior to assembly.

1. Connect the components of the extension assembly and tighten securely.
2. Screw the extension assembly into Control Valve Handle Assembly (3).
 - Tighten the extension securely.

Installation

Attach the Swivel Assembly [with thread sealant] to its delivery line. Tighten the connection securely.

Operation

WARNING

Should leakage occur anywhere within the system, disconnect power to the motor. Personal injury can occur.

Safety and Latch

1. Squeeze the Lever to ensure the safety engages properly.
2. Press the button in the center of the Lever and operate the Lever. The Lever should move to the open position.
3. Release the Lever (while pressing the button) then release the button to ensure the latch engages properly.
4. Press the Lever and release to release the latch.

If the safety and/or latch does not operate properly, refer to the **Troubleshooting Chart**.

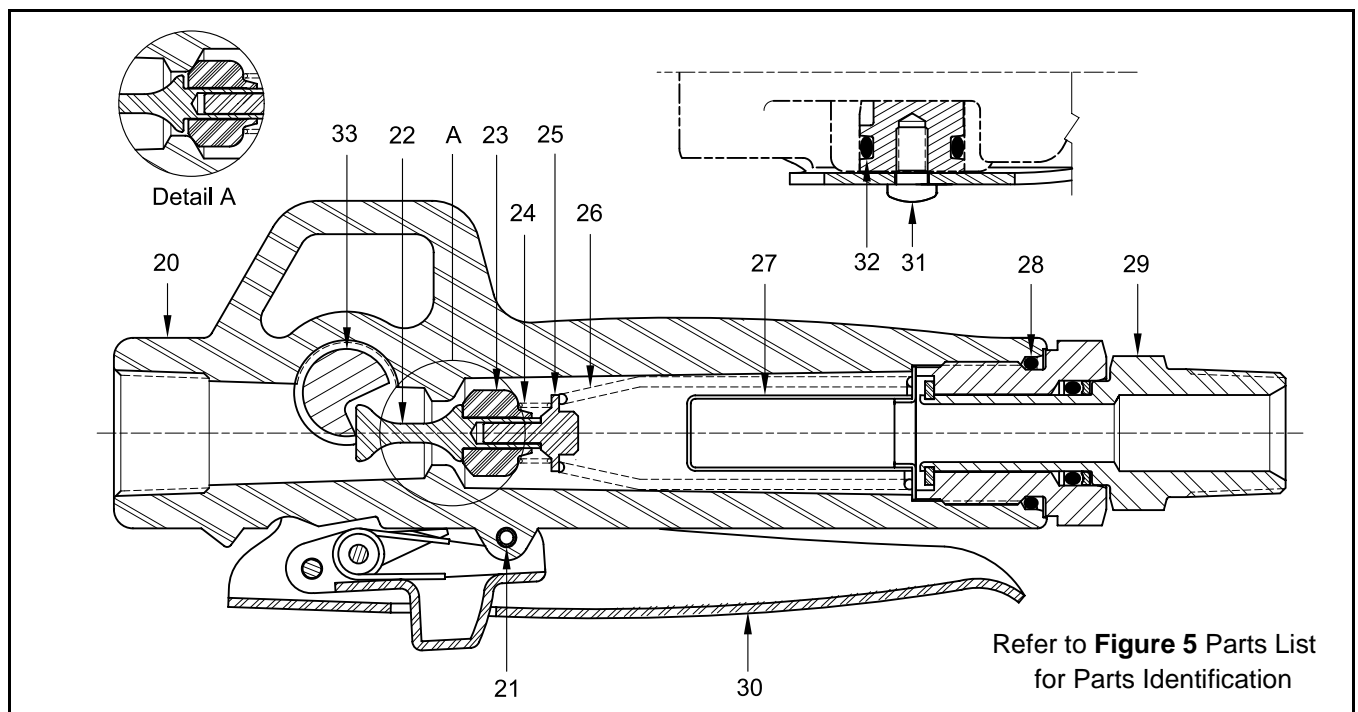

Figure 5 Control Valve Handle 339100 - Section View

Prime and Test

NOTE: Perform the following procedures at an air pressure that allows the pump to begin to cycle. Regulate the amount of air to the pump with a pressure regulator.

Should valve leakage occur at anytime, refer to the **Troubleshooting Chart**.

1. Point the control valve into an appropriate collection container.

2. Allow the pump to deliver fluid to the control valve.
 - The control valve should show no leakage nor dispense the product.
3. Cycle the control valve Lever Assembly several times.
 - Product should flow once air is eliminated from the control valve (and system).

If the control valve does not dispense the product, refer to the **Troubleshooting Chart**.

With the Lever in the released position, no product should appear at the Nozzle. If product does appear, refer to the **Troubleshooting Chart**.

Troubleshooting Chart

Control Valve Indications	Possible Problems	Solutions
Continuous product flow	<ol style="list-style-type: none"> 1. Foreign material on Seal (31) 2. Seal (31) worn or damaged 	<ol style="list-style-type: none"> 1. Disassemble, clean, and inspect seat area. Check mating surfaces and replace Seal (31) as necessary. Locate and eliminate source of foreign material. Clean Strainer (35) 2. Use Kit 393676
No product flow	Manual Nozzle (7 or 9) not open	Open Nozzle (7 or 9)
Leakage at Swivel Assembly (37)	<ol style="list-style-type: none"> 1. Initial tightening of Swivel Assembly (37) not sufficient 2. O-Ring (36) worn or damaged. 	<ol style="list-style-type: none"> 1. Tighten Swivel Assembly (37) 2. Replace O-Ring (36)
Leakage at Cam (41)	O-Rings (40) worn or damaged.	Replace O-Rings (40)
Leakage at front end of Nozzle	Nozzle damaged	Replace Nozzle
Leakage at Extension Assembly	<ol style="list-style-type: none"> 1. Initial tightening not sufficient 2. Thread sealant missing or inadequate 	<ol style="list-style-type: none"> 1. Tighten leaking connection 2. Apply thread sealant* to male pipe threads
Safety on Lever Assembly (38) does not engage	<ol style="list-style-type: none"> 1. Broken spring in Lever Assembly (38) 2. Foreign material in Lever Assembly (38) 3. Worn or damaged Compression Spring (34) 	<ol style="list-style-type: none"> 1. Use Kit 393677 2. Clean Lever Assembly (38) 3. Replace Compression Spring (34)
Latch on Lever Assembly (38) does not release	<ol style="list-style-type: none"> 1. Broken spring in Lever Assembly (38) 2. Foreign material in Lever Assembly (38) 3. Worn or damaged Compression Spring (34) 	<ol style="list-style-type: none"> 1. Use Kit 393677 2. Clean Lever Assembly (38) 3. Replace Compression Spring (34)
* Do not apply thread sealant to the first two (2) threads. Contamination can occur.		

Changes Since Last Printing

Added Model 7492-C