

Description

- Open hose reel for air, water (high or low pressure), oil or grease, depending on model.
- Uncoil the hose to the desired length. It can be locked by means of the latch mechanism.
- By gently pulling the hose, the latch is released and the hose is automatically recoiled.

WARNING: High pressure device for professional use only. Keep body clear of nozzle and hose. Serious injury could occur. Do not exceed max. W.P. or lowest rated system component. Disconnect air and release pressure in the system before servicing.

Installation:

1. Wall or ceiling mounted hose reel, directly or by using a pivoting bracket (Ref. 360 111) or a special bracket for installing several hose reels. (Ref. 360 115, 360 117, 360 118) (Fig. A).
2. For smooth operation and longer life, position reel mounting brackets as per figure B. This way, the hose is always pulled tangentially to the hose reel.
3. To move the hose guide arm and the hose outlet mouth, remove screws I (Fig. B), place arm and outlet in correct position and replace screws.

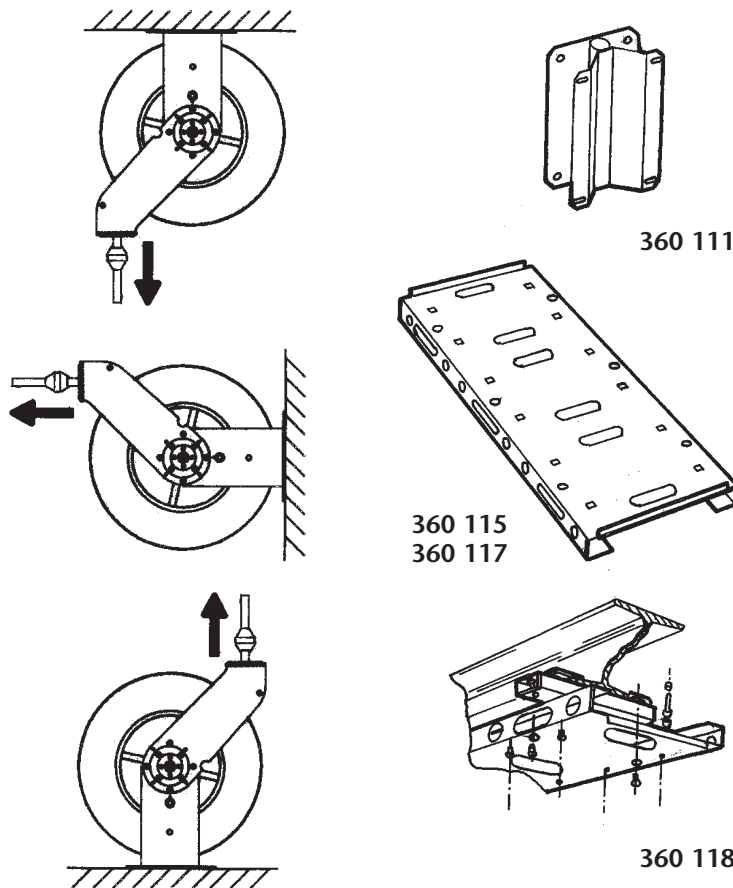

Fig.A

Fig.B



Hose Replacement

WARNING: Before removing the damaged hose, close the nearest shut off valve to the reel and open the fluid control gun to release the pressure inside the hose.

1. Dismounting the reel from its position is not required!
2. Using a 12mm Allen Key firmly hold the central shaft while removing the spring fastening screws (Fig. C). Using the wrench, allow the spring to gently turn counter clockwise, until the spring tension is fully released (Fig. F).
3. Uncoil the old hose and remove it from the reel. Remove the hose stopper.
4. Connect the new hose as indicated in Fig. E. Fix the hose stopper at the desired length.
5. Manually coil the hose until the hose stopper touches the roller bracket assembly.
6. Turn the key clockwise three or four times to obtain initial spring tension (Fig. D).
7. Holding the key firmly, replace the screws removed in step 1 (Fig. C).
8. Once the service gun is installed, verify that the spring tension is adequate. If not, proceed as indicated in steps 1, 5 and 6.

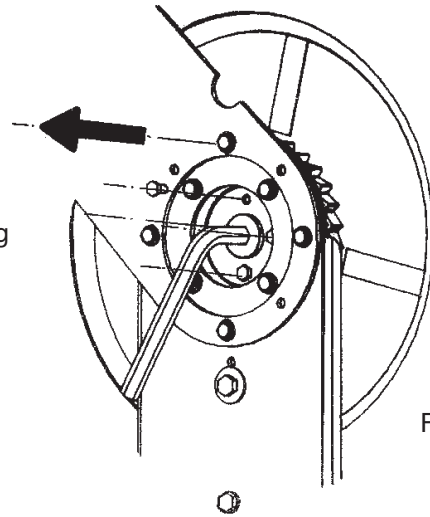

Fig. C/F

Hose Stopper Adjustment

1. To position the hose stopper at the appropriate length, uncoil the hose and latch it at the closest latching position.
2. Loosen the hose stopper and place it at the required position.

WARNING: Check that the reel is perfectly latched before removing the hose stopper.

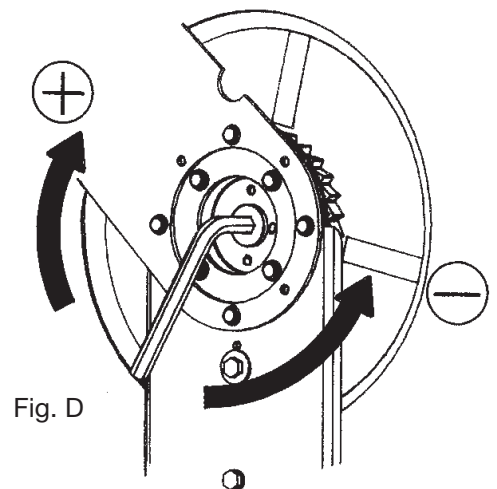
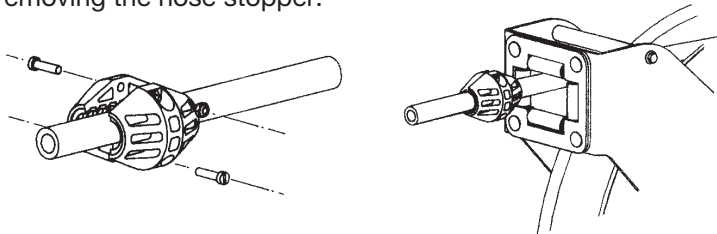

Fig. D

Spring Load Adjustment

Hose reels are supplied with a factory adjusted spring tension, depending on the hose installed. Reels without hose bear no spring tension. If the spring tension is to be adjusted afterwards, verify that the required hose length can be pulled out without stretching the spring to the limit. Minimum spring tension increases spring life.

PROCEDURE (See Figs. F & G).

1. With a fully coiled hose, remove the lateral support screw with an Allen key 4mm, insert a 12mm Allen key in the central shaft and hold it firmly. Remove the 4 spring fastening screws (Fig. F).
2. To increase spring load, turn wrench clockwise (Fig. G). To reduce spring load, turn wrench counterclockwise.
3. Firmly holding Allen key, replace the spring fastening screws. Replace the lateral support screw, without screwing it in completely, securing it with nut locker.

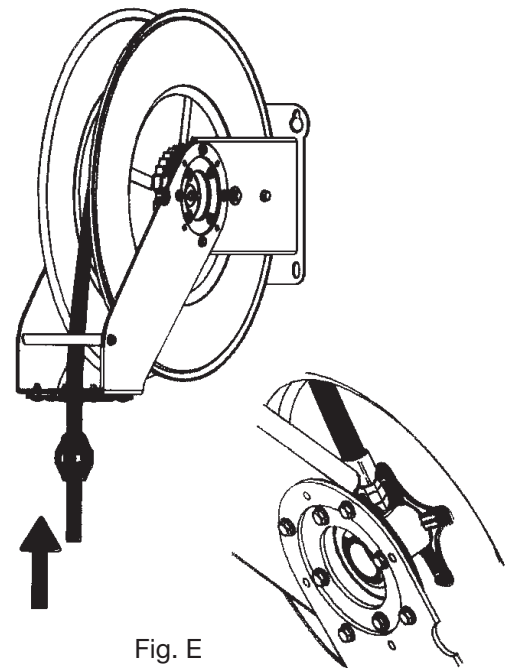

Fig. E

NSW
TEL: (02) 9939 0711
FAX: (02) 9939 0411

QLD/PNG
TEL: (07) 3204 9166
FAX: (07) 3204 1224

VIC/TAS
TEL: (03) 8787 8288
FAX: (03) 8787 8266

WA
TEL: (08) 9209 3066
FAX: (08) 9209 3933

SA/NT
TEL: (08) 8241 7111
FAX: (08) 8241 7011

NZ
TEL: (09) 447 1007
FAX: (09) 447 1008

Latch Replacement

1. To replace the latch, the hose reel should be dismantled from its position.
2. Release the spring tension as indicated in the hose replacement section.
3. Remove hose guide arms, by removing screws (I) which hold it to the base arms (Fig. H).
4. Remove the reel from the arms (Fig. I).
5. The latch mechanism and the spring can now be reached and replaced (Fig. J).
6. To assemble, follow these steps in the opposite direction.

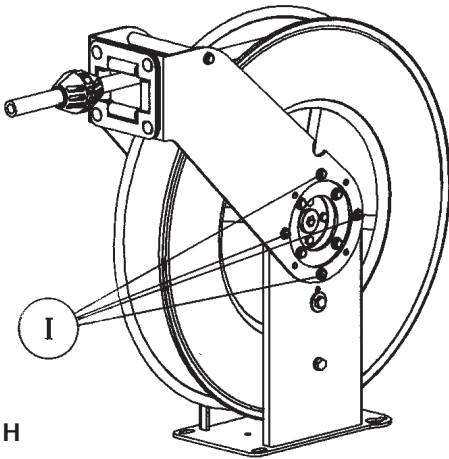

Fig. H

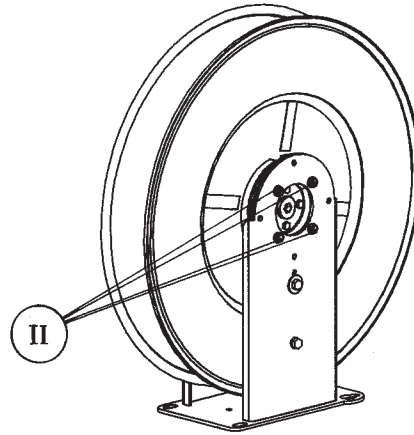

Fig. I

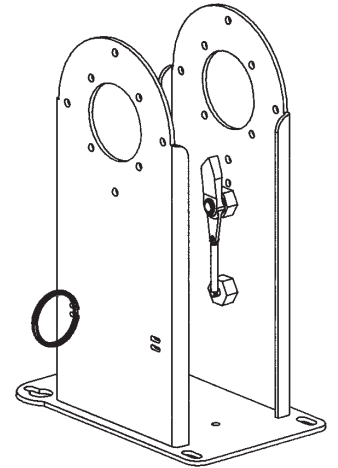

Fig. J

Swivel Replacement

WARNING: Before removing the old swivel, close the nearest shut off valve to the reel and open the fluid control gun to release the pressure inside the hose.

1. With a completely coiled hose (I), remove the fluid inlet hose (II) and the old swivel (Fig. K).
2. Replace with a new swivel. Insert the O-ring (grease swivel) or the V-seal (rest of applications) prior to assembling the swivel body, as per drawing (Fig. L). Slightly lubricate with grease the O-ring or the seal before inserting it.
3. To fasten the swivel, hold the reel spool while you tighten it (Fig. E).
4. Connect the inlet hose.

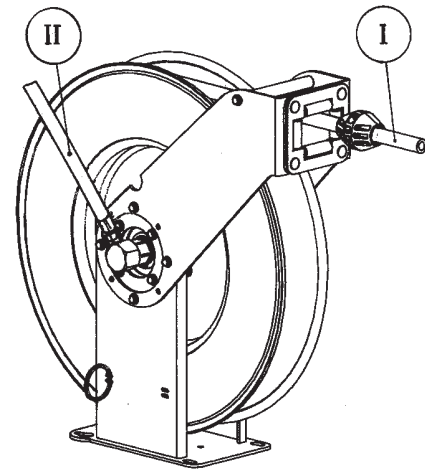

Fig. K

LUBRICATE BEFORE MOUNTING

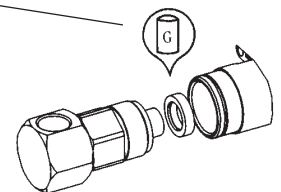

Fig. L

NSW
TEL: (02) 9939 0711
FAX: (02) 9939 0411

QLD/PNG
TEL: (07) 3204 9166
FAX: (07) 3204 1224

VIC/TAS
TEL: (03) 8787 8288
FAX: (03) 8787 8266



WA
TEL: (08) 9209 3066
FAX: (08) 9209 3933

SA/NT
TEL: (08) 8241 7111
FAX: (08) 8241 7011

NZ
TEL: (09) 447 1007
FAX: (09) 447 1008

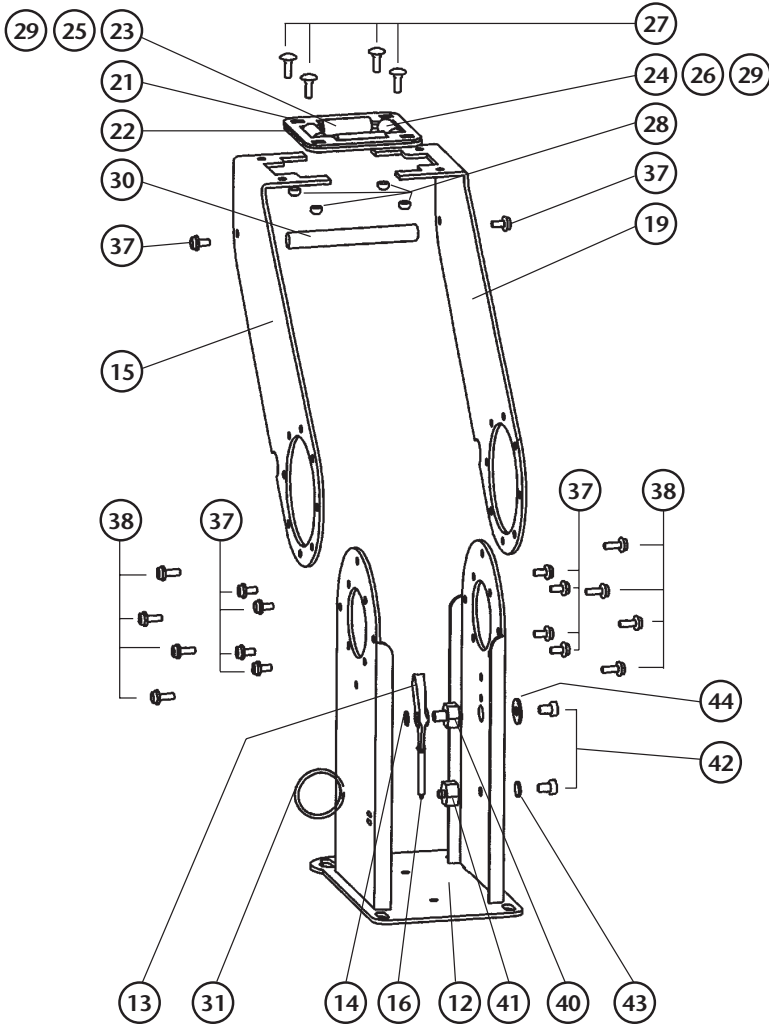
Parts And Drawing Breakdown For The 504200

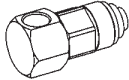
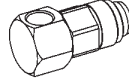
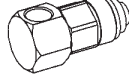

-  **45** OIL/AIR
ACEITE/AIRE
LUBRIFIANTS/AIR
ÖL/LUFT
-  **46** GREASE/GRASA/GRAISSE/FETT
-  **47** HIGH PRESSURE WATER
AGUA A ALTA PRESIÓN
EAU À HAUTE PRESSION
DRUCKWASSER
-  **48** HOSE STOPPER
TOPE MANGUERA
BUTÉE D' ARRÊT
SCHLAUCHSTOPPER

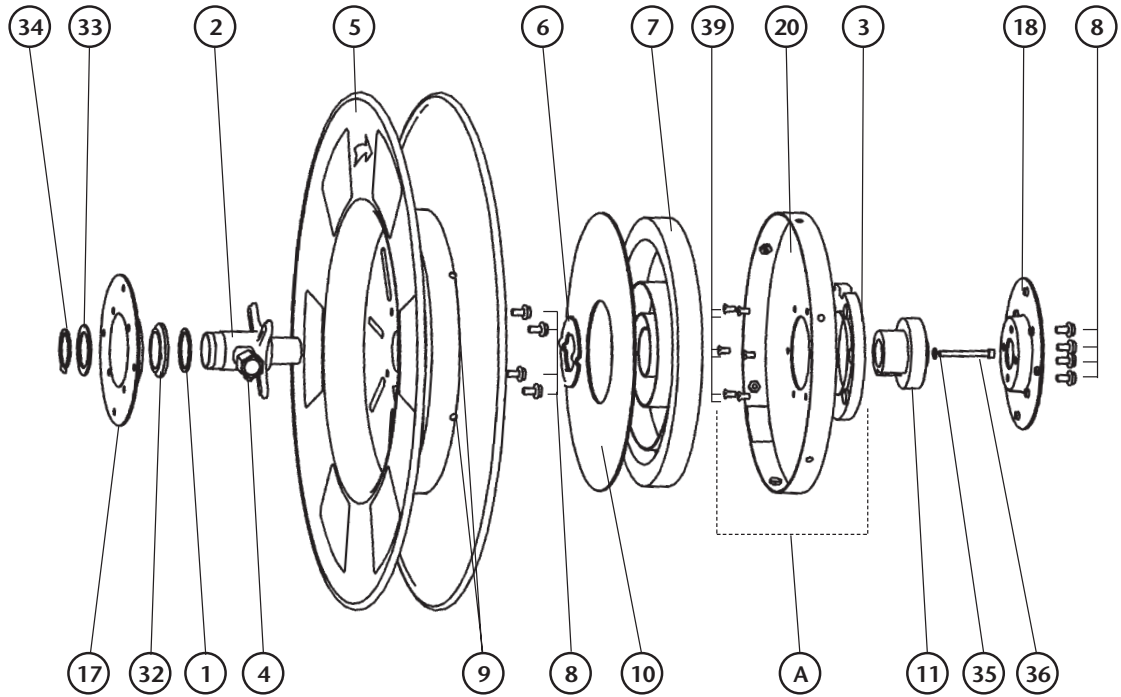

NSW TEL: (02) 9939 0711 FAX: (02) 9939 0411	QLD/PNG TEL: (07) 3204 9166 FAX: (07) 3204 1224	VIC/TAS TEL: (03) 8787 8288 FAX: (03) 8787 8266	WA TEL: (08) 9209 3066 FAX: (08) 9209 3933	SA/NT TEL: (08) 8241 7111 FAX: (08) 8241 7011	NZ TEL: (09) 447 1007 FAX: (09) 447 1008
---	---	---	--	---	--

Parts And Drawing Breakdown For The 504200

Ordering Spare Parts

Parts List – Part No. 504200

Item Number	Part Number	Product Description	Qty
1	735 211	Washer	1
2	750 201	Shaft	1
3	750 100	Ratchet	1
4	750 205	Outlet Adap.	1
5	750 241	Reel assembly	1
6	750 207	Spring washer	1
7	850 303	Spring	1
8	940 321	M6x14 DIN 7380 screw	8
9	940 910	M5x8 DIN 964 screw	6
10	750 264	Spring Disc	1
11	750 101	Spring hub	1
12	750 609	Base	1
13	850 104	Latch	1
14	942 610	A-10 DIN 471 washer	1
15	750 622	Left arm	1
16	850 301	Latch spring	1
17	750 616	Swivel side supplement	1
18	750 617	Latch side supplement	1
19	750 621	Right arm	1
20	750 214	Spring cover	1
21	750 603	Upper hose roller bracket	1
22	750 604	Lower hose roller bracket	1
23	750 605	Long hose roller shaft	2
24	750 606	Short hose roller shaft	2
25	850 601	Horizontal hose roller	2
26	850 602	Vertical hose roller	2
27	940 822	M6 x 20 DIN 603 screw	4
28	941 106	M6 DIN 985 nut	4
29	942 004	4.3 DIN 125 washer	8
30	750 618	Rod	1
31	850 302	Inlet hose ring	1
32	850 600	Axis holder	1
33	750 228	Axis washer	1
34	942 636	A-36 DIN 471 washer	1
35	942 005	5.3 DIN 125 washer	1
36	940 311	M5 x 50 DIN 912 screw	1
37	940 027	M6 x 12 DIN 6921 screw	10
38	940 028	M6 x 15 DIN 6921 screw	8
39	940 912	M5 x 10 DIN 963 screw	6
40	750 613	Latch axe	1
41	750 614	Spring latch bolt	1
42	940 036	M 8 x 12 DIN 933 screw	2
43	942 208	B 8 DIN 127 washer	1
44	942 108	B 8,4 DIN 9021 washer	1
A	750 202	Spring cover assembly	1
45	750 266	Swivel	

NSW

TEL: (02) 9939 0711
FAX: (02) 9939 0411

QLD/PNG

TEL: (07) 3204 9166
FAX: (07) 3204 1224

VIC/TAS

TEL: (03) 8787 8288
FAX: (03) 8787 8266

WA

TEL: (08) 9209 3066
FAX: (08) 9209 3933

SA/NT

TEL: (08) 8241 7111
FAX: (08) 8241 7011

NZ

TEL: (09) 447 1007
FAX: (09) 447 1008